

FRAME & GRATE, MASONRY ADJUSTMENT TO GRADE BY CONTRACTOR IN THE FIELD.

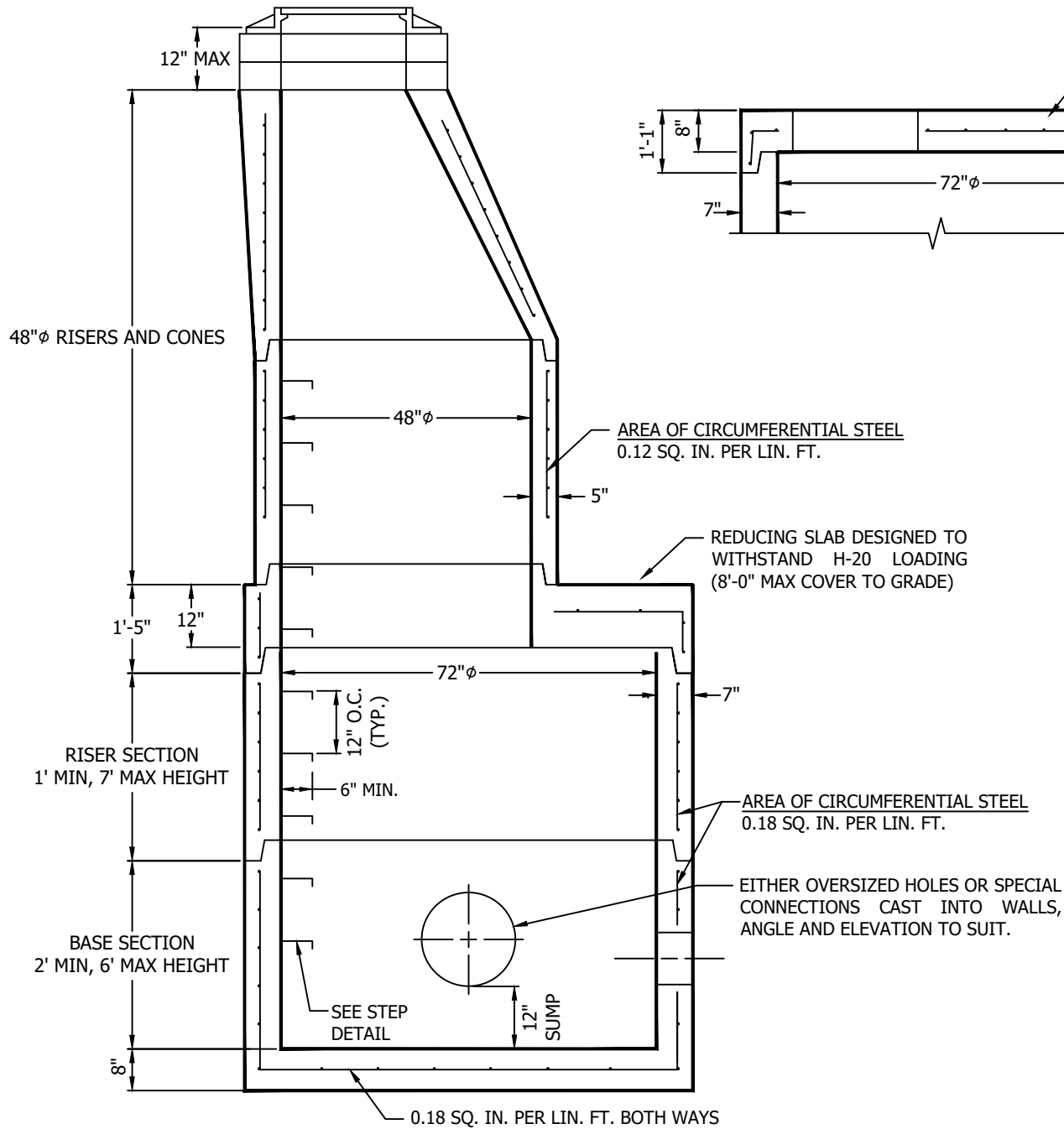

MA INDUSTRIES MODEL #PS2-PF STEEL REINFORCED COPOLYMER POLYPROPYLENE PLASTIC STEP. CONFORMS TO NYSDOT.

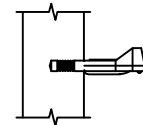

STEP DETAIL
NTS

BUTYL RUBBER JOINT SEALANT PER FEDERAL SPECIFICATION NO. SS-S-00210.

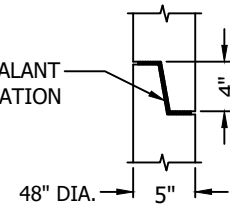

JOINT DETAIL
NTS

NOTES:

- 1) CONCRETE TO TEST 4000 PSI AT 28 DAYS.
- 2) ALL MATERIAL IN STRICT COMPLIANCE WITH ASTM C478, LATEST REVISION.
- 3) MAX TWO (2) LIFTING HOLES IN EACH SECTION TO FACILITATE HANDLING.
- 4) ALL COMPONENTS ARE MANUFACTURED IN ACCORDANCE WITH NYSDOT SPECIFICATIONS.

SECTION VIEW

3/8" = 1'-0"

WEIGHT
____ **POUNDS**

	276 Clove Road Salisbury Mills, New York, 12577 www.arconcrete.com 845-562-0640	
	72" ϕ MANHOLE	DATE: 8/30/2022 REV.: --- DWN.BY: A&R LLC DWG. NO.: 72MH
CONTRACTOR: ---		